



# PROJECT CONCEPT NOTE

## CARBON OFFSET UNIT (CoU) PROJECT

<b>Title</b>	: 1.2 MW Small Scale Hydro Power project by M/s Flowgen Renewable Energy Pvt. Ltd.
<b>Version</b>	: 1.0
<b>PCN Date</b>	: 23/12/2022
<b>CoU Issuance Period</b>	: 20 Years
<b>Monitoring Duration</b>	: 11/01/2021 to 31/12/2040



**Project Concept Note (PCN)**  
**CARBON OFFSET UNIT (CoU) PROJECT**

**BASIC INFORMATION**

<b>Title of the project activity</b>	1.2 MW Small Scale Hydro Power project by M/s Flowgen Renewable Energy Pvt. Ltd.
<b>Scale of the project activity</b>	Small Scale
<b>Completion date of the PCN</b>	23/12/2022
<b>Project participants</b>	Creduce Technologies Private Limited (Project Aggregator) M/s Flowgen Renewable Energy Pvt. Ltd. (Project Owner)
<b>Host Party</b>	India
<b>Applied methodologies and standardized baselines</b>	Applied Baseline Methodology: AMS-I. D: “Grid connected renewable electricity generation”, version 18  Standardized Methodology: Not Applicable.
<b>Sectoral scopes</b>	01 Energy industries  (Renewable/Non-Renewable Sources)
<b>Estimated amount of total GHG emission reductions</b>	To be estimated during verification  [An ex-ante estimate is 3,784 CoUs per year]

## **SECTION - A - Description of project activity**

### **A.1 General description of Carbon offset Unit (CoU) project activity**

The proposed project titled under UCR is “1.2 MW Small Scale Hydro Electric Power project by M/S Flowgen Renewable Energy Pvt. Ltd.”, which is a Hydro Electric Power project located in Suma Ropa Village, Kullu district in the state of Himachal Pradesh (India). The project is an operational activity with continuous reduction of GHG, currently being applied under “Universal Carbon Registry” (UCR).

#### **A.1.1 Purpose of the project activity:**

The project activity is a renewable power generation activity that incorporates the installation and operation of two hydro turbines, having aggregated installed capacity of 1.2 MW in the district Kullu of the state of Himachal Pradesh in India. This project has been promoted by M/S Flowgen Renewable Energy Pvt. Ltd. This project activity is also called as Jail Small Hydro Electric Power Project.

Sr. No.	Turbine	Installed Capacity	Commissioning Date
1	Unit-I	600 kW	11/01/2021
2	Unit-II	600 kW	11/01/2021

The Hydro Electric Turbines were commissioned by the Himachal Pradesh State Electricity Board Ltd (HPSEBL), Government of Himachal Pradesh, India.

Jail Small Hydropower Project has been contemplated as Run-of –River scheme on Jail Nallah a tributary of the Parbati river in Kullu Sub-division of Kullu district Himachal Pradesh. The stream originated from an altitude of 3519 meters. The catchment area of Jail Small Hydro Project above the proposed weir site is 6.31 Sq. Km. The area on both sides of the Stream is hilly with steep slopes. For diversion of Jail nallah inflows, trench weir is proposed at El  $\pm$  2050 m. The size of weir has been proposed as 10 m long and 5.0 m wide to draw a design discharge of 0.37cumecs. The project activity aims to harness kinetic energy of water (renewable source) to generate electricity. The project comprises a Trench weir which diverts the water into an intake placed on the right bank of the river. The diverted water passes through Desilting basin. Desilted water enters into water conductor system, forebay and the steel pressure shaft. A surface powerhouse is suitably located on a terrace at right bank of the river. The net head generated was 385.60 m. Tail water from the powerhouse is discharged back into the nallah. The project activity has been commissioned on 11/01/2021.

As the nature of the hydro project, no fossil fuel is involved for power generation in the project activity except a nominal operation of diesel gen-sets for emergency and/or as a backup arrangement. The electricity produced by the project is directly contributing to climate change mitigation by reducing the anthropogenic emissions of greenhouse gases in to the atmosphere by displacing an equivalent amount of power at grid, which would otherwise have been generated from fossil fuel-based power plants which are connected to the Indian grid system.

The net generated electricity from the project activity is sold to state electricity board under the Power Purchase Agreement (PPA) signed between the project owner and the utility. In pre- project scenario, electricity delivered to the grid by the project activity would have otherwise been generated by the

operation of fossil fuel-based grid-connected power plants and by the addition of new generation sources in the grid.

Hence, project activity is displacing the estimated annual net electricity generation i.e., 4,204 MWh from the regional grid, which otherwise would have been generated by the operation of fossil fuel-based grid-connected power plants. The estimated annual average and the total CO<sub>2</sub>e emission reductions by the project activity are expected to be 3,784 tCO<sub>2</sub>e.

The estimated annual average and the total CO<sub>2</sub>e emission reductions by the project activity is expected to be 3,784 tCO<sub>2</sub>e, whereas actual emission reduction achieved during the first CoU period shall be submitted as a part of first monitoring and verification.

Since the project activity will generate electricity through hydro energy, a clean renewable energy source it will not cause any negative impact on the environment and thereby contributes to climate change mitigation efforts.

### **A.1.2 Project's Contribution to Sustainable Development**

This project is a greenfield activity where grid power is the baseline. The Indian grid system has been predominantly dependent on fossil fuel-powered plants. Renewable power generation is gradually contributing to the share of clean & green power in the grid; however, the grid emission factor is still on the higher side which defines the grid as a distinct baseline.

The Government of India has stipulated the following indicators for sustainable development in the interim approval guidelines for such projects which are contributing to GHG mitigations. The Ministry of Environment, Forests & Climate Change, has stipulated economic, social, environmental, and technological well-being as the four indicators of sustainable development. It has been envisaged that the project shall contribute to sustainable development using the following ways:



**Social well-being:** The project would help in generating direct and indirect employment benefits accruing out of ancillary units for project equipment's and Hydro Turbines and for maintenance during the operation of the project activity. It will lead to the development of infrastructure around the project area in terms of improved road network etc. and will also directly contribute to the development of renewable infrastructure in the region.

**Economic well-being:** The project is a clean technology investment decision based on carbon revenue support, which signifies the flow of clean energy investments into the host country. The project activity requires temporary and permanent, skilled and semi-skilled manpower at the project location; this will create additional employment opportunities in the region. The generated electricity will be displacing an equivalent amount of electricity that otherwise would have been generated by fossil fuel sources, thereby reducing grid emission. In addition, improvement in infrastructure will provide new opportunities for industries and economic activities to be set up in the area. Apart from getting better employment opportunities, the local people will get better prices for their land, thereby resulting in overall economic development.

**Technological well-being:** The project activity employs state of art technology hydro turbines which has high power generation potential. The successful operation of project activity would lead to the

promotion of this technology and would further push R&D efforts by technology providers to develop more efficient and better machinery in the future. Hence, the project leads to technological well-being.

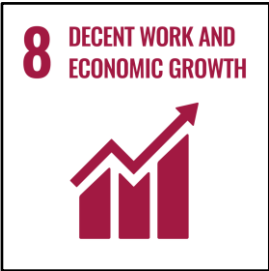
**Environmental well-being:** The project activity will generate power using zero emissions hydro-based power generation facility which helps to reduce GHG emissions and specific pollutants like SOx, NOx, and SPM associated with the conventional thermal power generation facilities. The project utilizes kinetic energy of flowing water for generating electricity which is a clean source of energy. The project activity will not generate any air pollution, water pollution or solid waste to the environment which otherwise would have been generated through fossil fuels. Thus, the project causes no negative impact on the surrounding environment contributing to environmental well-being.

SDG Goals	Description
<p data-bbox="256 689 344 723">Goal 7</p> <div data-bbox="169 752 438 1021">  <p data-bbox="188 775 395 835"><b>7</b> AFFORDABLE AND CLEAN ENERGY</p> </div>	<ul style="list-style-type: none"> <li data-bbox="481 674 1461 757">➤ The project activity will generate clean energy, which with increased shared will increase the affordability at a cheaper rate to end user.</li> <li data-bbox="481 779 1461 981">➤ The project activity will utilize hydro energy (renewal resource) to generate power. The project activity will increase the share of renewable resource-based electricity to global mix of energy consumption</li> </ul>
<p data-bbox="256 1077 344 1111">Goal 8</p> <div data-bbox="169 1137 438 1406">  <p data-bbox="188 1160 416 1220"><b>8</b> DECENT WORK AND ECONOMIC GROWTH</p> </div>	<ul style="list-style-type: none"> <li data-bbox="481 1077 995 1111">➤ Decent work and economic growth.</li> <li data-bbox="481 1155 1461 1406">➤ This project activity generates additional employment for skilled and unskilled, also the project situated in remote area will provide employment opportunities to unskilled people from villages. The training on various aspect including safety, operational issues and developing skill set will also be provided to employees</li> </ul>
<p data-bbox="240 1471 344 1505">Goal 13</p> <div data-bbox="169 1532 438 1800">  <p data-bbox="188 1554 331 1615"><b>13</b> CLIMATE ACTION</p> </div>	<ul style="list-style-type: none"> <li data-bbox="481 1471 1461 1554">➤ This 1.2 MW Flowgen hydro meet the SDG 13 goal by saving fossil fuel and produce clean energy.</li> <li data-bbox="481 1603 1406 1637">➤ This project is expected to reduce CO<sub>2</sub> emission 3,784 ton per year.</li> <li data-bbox="481 1682 1350 1715">➤ <b>SDG 13</b> on clean energy is closely related and complementary.</li> <li data-bbox="481 1760 1461 1966">➤ In a Greenfield project, electricity delivered to the grid by the project would have otherwise been generated by the operation of grid-connected power plants. Thereby the project activity reduces the dependence on fossil fuel based generation units and as there are no</li> </ul>

	associated emissions with this project it contributes to the reduction of greenhouse gases (GHG) emissions.
--	---

**A.1.3 With regards to ESG credentials:**

At present specific ESG credentials have not been evaluated, however, the project essentially contributes to various indicators which can be considered under ESG credentials. Some of the examples are as follows:

- **Under Environment:**

Environmental criteria may include a company’s energy use, waste, pollution, natural resource conservation, and treatment of animals, etc. For the project proponent, the energy use pattern is now based on renewable energy due to the project and it also contributes to GHG emission reduction and conservation of depleting energy sources associated with the project baseline. Also, the criteria can be further evaluated on the basis of any environmental risks that the company might face and how those risks are being managed by the company. Here, as the power generation will be based on hydropower, the risk of environmental concerns associated with non-renewable power generation and risk related to increasing cost of power, etc. are now mitigated. Hence, the project contributes to ESG credentials.

- **Under Social:**

Social criteria reflect on the company’s business relationships, qualitative employment, working conditions with regard to its employees’ health and safety, interests of other stakeholders etc. With respect to this project, the Project Proponent has robust policies in place to ensure equitable employment, health & safety measures, local jobs creation etc. Also, the organizational CSR activities directly support local stakeholders to ensure social sustainability. Thus, the project contributes to ESG credentials.

- **Under Governance:**

Governance criteria relates to overall operational practices and accounting procedure of the organization. With respect to this project, the Project Proponent practices a good governance practice with transparency, accountability and adherence to local and national rules & regulations etc. This can be further referred from the company’s annual report. The electricity generated from the project can be accurately monitored, recorded and further verified under the existing management practice of the company. Thus, the project and the proponent ensure good credentials under ESG.

**A.2 Do no harm or Impact test of the project activity**

There was no harm identified from the project and hence no mitigations measures are applicable.

Rational: as per ‘Central Pollution Control Board (Ministry of Environment & Forests, Govt. of India)’, final document on revised classification of Industrial Sectors under Red, Orange, Green and White Categories (07/03/2016), it has been declared that hydro project activity falls under the “White category”. White Category projects/industries do not require any Environmental Clearance such as ‘Consent to Operate’ from PCB as such project does not lead to any negative environmental impacts.

Additionally, as per Indian Regulation, Environmental and Social Impact Assessment is not required for Hydro Projects.

Additionally, there are social, environmental, economic and technological benefits which contribute to sustainable development. The key details have been discussed in the previous section.

### A.3 Location of the project activity

Country	:	India
State	:	Himachal Pradesh
District	:	Kullu
Tehsil	:	Bhunter
Town/Village	:	Suma Ropa

Jail Small Hydro Power Project is accessed via Kullu-Manikaran Road. Powerhouse is proposed on jail stream near to Kasol Village on left bank of Jail Nallaha. The road from Jail onwards approaches all the proposed components of the Project. Nearest railway station is at broad-gauge at Kirtpur, Nearest airport is at Kullu. The geographic co-ordinate of the project locations is 32°00'20.8"N and 77°17'24.6"E.

The representative location map is shown below

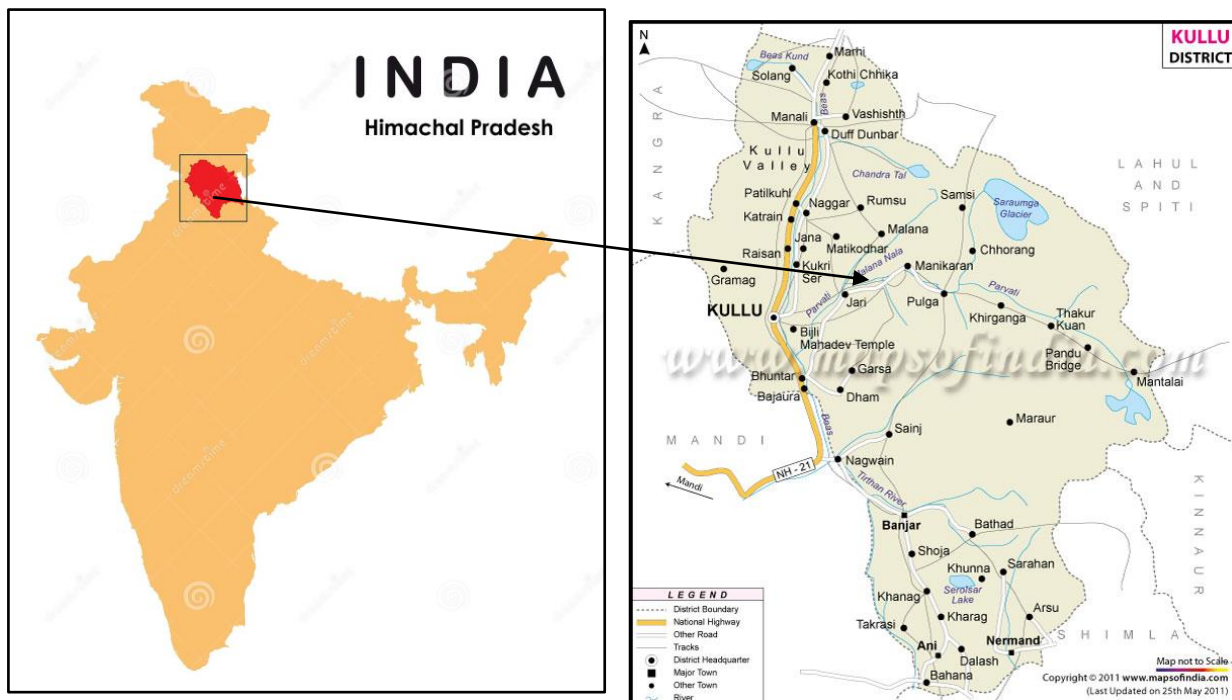

Figure-1- Location of the project activity (courtesy: google images and [www.mapofindia.com](http://www.mapofindia.com))

### A.4 Technologies/measures

The project activity involves 2 numbers hydro turbine generators of Pelton Horizontal type (600

KW each) with internal electrical lines connecting the project activity with local evacuation facility. The generators generate power at 3.3kV, which can further be stepped up to 33 KV. The project activity can operate in the frequency range of 50 Hz and in the voltage range of 3.3kV  $\pm$  10%. The average life time of the generator is around 40 years as per the equipment supplier specification. The other salient features of the technology are:

Design Discharge	0.37 cumecs
Gross Head	408.470 m
Net Head	385.60 m
Diversion Weir	
Type	Trench weir
Shape	Rectangular
Length	20 m
Turbine Type	Horizontal Pelton
Speed of turbine	750 rpm
Step-up Transformer	2 NO, 3.3/33 kV 800 KVA each, 3 phase
Generators	Synchronous
Excitation System	(SESR) Self Excited Self-Regulated Brushless
Tail Race	Rectangular
Size	0.70 m x 0.70 m including 0.18 m freeboard, $\pm$ 12 m Length
Number	2 No. Joining into one
Bed Slope	1 in 250 m
EL at end	1639.952 m
Penstock	
Dia at main	430 mm
Dia at Bifurcation	300 mm
Length	1245 m
Number	One penstock bifurcated into two near power house
Plate Thickness	8 mm to 12 mm
Velocity	3.06 m/sec
Dia at Bell Mouth	0.650 m
Design Flood	51.76 Cums
Maximum Observed Discharge	2.31 cumcs
Total Catchment area	6.31 sq kms
Type of Catchment	Snow fed and Rain fed
Peak	3519 m
D tank	20 m x 4.0 m (1.49 m depth at start and 1.78m depth at end including 0.50 m freeboard and hopper depth)
Flow through velocity	0.15 m/sec
Width of drain	0.30 m
Forebay Size	5.0 m x 4.0 m x 5.0 m including 0.50 m free board

In the absence of the project activity, the equivalent amount of electricity imported from the NEWNE grid would have been generated from the NEWNE grid, which is predominantly based on fossil fuels<sup>1</sup>, hence baseline scenario of the project activity is the grid-based electricity system, which is also the pre-

<sup>1</sup> [http://www.cea.nic.in/executive\\_summary.html](http://www.cea.nic.in/executive_summary.html)

project scenario.

### A.5 Parties and project participants

Party (Host)	Participants
India	<p><b>Creduce Technologies Private Limited (Aggregator)</b>  <b>Contact person</b> : Shailendra Singh Rao  <b>Mobile</b> : +91 9016850742, 9601378723  <b>Address</b> : 2-O-13,14 Housing Board Colony, Banswara, Rajasthan -327001, India</p> <p><b>M/S Flowgen Renewable Energy Pvt. Ltd. (Project Owner)</b>  <b>Address:</b> 137, Pritam Nagar, Tehsil-Battiyata, District- Kangra, Himachal Pradesh-176001</p>

### A.6 Baseline Emissions

The baseline scenario identified at the PCN stage of the project activity is:

In the absence of the project activity, the equivalent amount of electricity would have been imported from the grid (which is connected to the unified Indian Grid system (NEWNE Grid)), which is carbon intensive due to being predominantly sourced from fossil fuel-based power plants. Hence, the baseline scenario of the project activity is the grid-based electricity system, which is also the pre-project scenario.

Schematic diagram showing the baseline scenario:

#### Baseline Scenario:

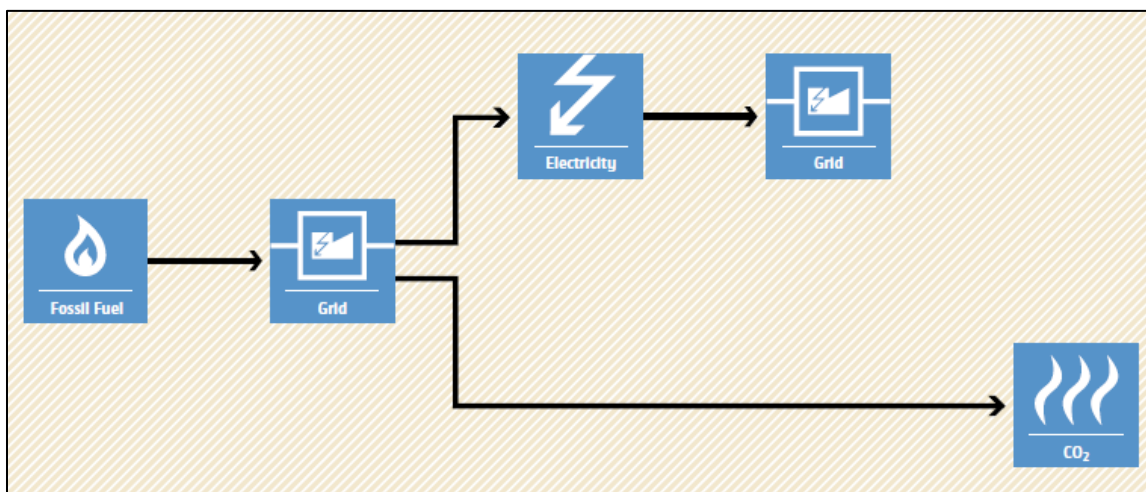

#### Project Scenario:

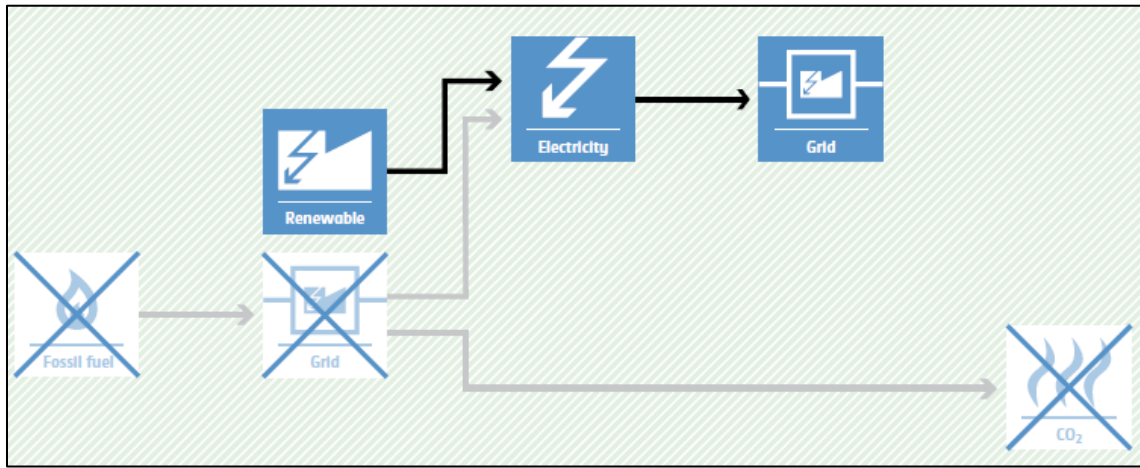

### A.7 De-bundling

This project activity is not a de-bundled component of a larger project activity.

## SECTION - B - Application of methodologies and standardized baselines

### B.1 Reference to methodologies and standardized baselines

<b>Sectoral scope</b>	:	01, Energy industries (Renewable/Non-renewable sources)
<b>Type</b>	:	I-Renewable Energy Projects
<b>Category</b>	:	AMS. I.D. (Title: “Grid connected renewable electricity generation”, version 18)

### B.2 Applicability of methodologies and standardized baselines

The project activity involves generation of grid connected electricity from the construction and operation of a new hydro power-based power project. The project activity has installed capacity of 1.2 MW which will qualify for a small-scale project activity under Type-I of the Small-Scale methodology. The project status is corresponding to the methodology AMS-I.D., version 18 and the applicability of the methodology is discussed below:

Applicability Criterion	Project Case
<p>1. This methodology comprises renewable energy generation units, such as photovoltaic, hydro, tidal/wave, wind, geothermal and renewable biomass:</p> <p>(a) Supplying electricity to a national or a regional grid; or</p> <p>(b) Supplying electricity to an identified consumer facility via national/regional grid through a contractual arrangement such as wheeling.</p>	<p>The project activity is a Renewable Energy Project which falls under applicability criteria option 1 (a) i.e., “Supplying electricity to a national or a regional grid”.</p> <p>Hence the project activity meets the given applicability criterion.</p>
<p>2. This methodology is applicable to project activities that:</p> <p>(a) Install a Greenfield plant;</p> <p>(b) Involve a capacity addition in (an) existing plant(s);</p> <p>(c) Involve a retrofit of (an) existing plant(s);</p> <p>(d) Involve a rehabilitation of (an) existing plant(s)/unit(s); or</p> <p>(e) Involve a replacement of (an) existing plant(s).</p>	<p>The option (a) of applicability criteria 2 is applicable as project is a Greenfield plant /unit. Hence the project activity meets the given applicability criterion.</p>

Applicability Criterion	Project Case
<p>3. Hydro power plants with reservoirs that satisfy at least one of the following conditions are eligible to apply this methodology:</p> <p>a) The project activity is implemented in existing reservoir, with no change in the volume of the reservoir; or</p> <p>b) The project activity is implemented in existing</p> <p>c) reservoir, where the volume of the reservoir(s) I increased and the power density as per definitions given in the project emissions section, is greater than 4 W/m<sup>2</sup>.</p> <p>d) The project activity results in new reservoirs and the power density of the power plant, as per definitions given in the project emissions section, is greater than 4 W/m<sup>2</sup></p>	<p>It is run of river type of project; hence, this criterion is not applicable.</p>
<p>4. If the new unit has both renewable and non-renewable components (e.g., a wind/diesel unit), the eligibility limit of 15 MW for a small-scale CDM project activity applies only to the renewable component. If the new unit co-fires fossil fuel, the capacity of the entire unit shall not exceed the limit of 15 MW.</p>	<p>The proposed project is 1.2 MW Hydro power project, i.e., only component is renewable power project below 15 MW, thus the criterion is not applicable to this project activity.</p>
<p>5. Combined heat and power (co-generation) systems are not eligible under this category.</p>	<p>The project is Hydro Power Project and thus, the criterion is not applicable to this project activity.</p>
<p>6. In the case of project activities that involve the capacity addition of renewable energy generation units at an existing renewable power generation facility, the added capacity of the units added by the project should be lower than 15 MW and should be physically distinct from the existing units.</p>	<p>The proposed project is a greenfield 1.2 MW Hydro Power Project, i.e., no capacity addition was done to any existing power plant. Thus, this criterion is not applicable to this project activity.</p>
<p>7. In the case of retrofit, rehabilitation or replacement, to qualify as a small-scale project, the total output of the retrofitted, rehabilitated or replacement power plant/unit shall not exceed the limit of 15 MW.</p>	<p>The proposed project is a greenfield 1.2 MW Hydro Power Project, i.e., no retrofit, rehabilitation or replacement was done to any existing power plant. Thus, this criterion is not applicable to this project activity.</p>

Applicability Criterion	Project Case
8. In the case of landfill gas, waste gas, wastewater treatment and agro-industries projects, recovered methane emissions are eligible under a relevant Type III category. If the recovered methane is used for electricity generation for supply to a grid, then the baseline for the electricity component shall be in accordance with procedure prescribed under this methodology. If the recovered methane is used for heat generation or cogeneration other applicable Type-I methodologies such as “AMS-I.C.: Thermal energy production with or without electricity” shall be explored.	The proposed project is a greenfield 1.2 MW Hydro Power Project hence, this criterion is not applicable to this project activity.
9. In case biomass is sourced from dedicated plantations, the applicability criteria in the tool “Project emissions from cultivation of biomass” shall apply.	No biomass is involved, the project is only a Hydro Power Project and thus the criterion is not applicable to this project activity.

### B.3 Applicability of double counting emission reductions

There is no double accounting of emission reductions in the project activity due to the following reasons:

- Project is uniquely identifiable based on its location coordinates,
- Project has a dedicated commissioning certificate and connection point,
- Project is associated with dedicated energy meters

### B.4 Project boundary, sources, and greenhouse gases (GHGs)

As per applicable methodology AMS-I.D. Version 18, “The spatial extent of the project boundary includes the project power plant and all power plants connected physically to the electricity system that the project power plant is connected to.”

Thus, the project boundary includes the Hydro Power Plant and the Indian grid system.

Source		Gas	Included?	Justification/Explanation
Baseline	Grid connected electricity generation	CO <sub>2</sub>	Yes	Main emission source
		CH <sub>4</sub>	No	Minor emission source
		N <sub>2</sub> O	No	Minor emission source

Source		Gas	Included?	Justification/Explanation
		Other	No	No other GHG emissions were emitted from the project
Project	Greenfield Hydro Electric Power project Activity	CO <sub>2</sub>	No	No CO <sub>2</sub> emissions are emitted from the project
		CH <sub>4</sub>	No	Project activity does not emit CH <sub>4</sub>
		N <sub>2</sub> O	No	Project activity does not emit N <sub>2</sub> O
		Other	No	No other emissions are emitted from the project

## B.5 Establishment and description of the baseline scenario

As per the approved consolidated methodology AMS-I.D. Version 18, if the project activity is the installation of a new grid-connected renewable power plant/unit, the baseline scenario is the following:

“The baseline scenario is that the electricity delivered to the grid by the project activity would have otherwise been generated by the operation of grid-connected power plants and by the addition of new generation sources into the grid”.

The project activity involves setting up a new hydro power plant to harness kinetic energy of flowing water. In the absence of the project activity, the equivalent amount of power would have been supplied by the Indian grid, which is fed mainly by fossil fuel-fired plants. Hence, the baseline for the project activity is the equivalent amount of power produced at the Indian grid.

A "grid emission factor" refers to a CO<sub>2</sub> emission factor (tCO<sub>2</sub>/MWh) that will be associated with each unit of electricity provided by an electricity system. The UCR recommends an emission factor of 0.9 tCO<sub>2</sub>/MWh for the 2013 - 2020 years as a fairly conservative estimate for Indian projects not previously verified under any GHG program. Also, for the vintage 2021, the combined margin emission factor calculated from the CEA database in India results in higher emissions than the default value. Hence, the same emission factor has been considered to calculate the emission reduction under a conservative approach.

### B.5.1 Net GHG Emission Reductions and Removals

Thus,  $ER_y = BE_y - PE_y - LE_y$

Where:

$ER_y$  = Emission reductions in year y (tCO<sub>2</sub>/y)

$BE_y$  = Baseline Emissions in year y (t CO<sub>2</sub>/y)

$PE_y$  = Project emissions in year y (tCO<sub>2</sub>/y)

$LE_y$  = Leakage emissions in year y (tCO<sub>2</sub>/y)

- **Baseline Emissions**

Baseline emissions include only CO<sub>2</sub> emissions from electricity generation in power plants that are displaced due to the project activity. The methodology assumes that all project electricity generation above baseline levels would have been generated by existing grid-connected power plants and the addition of new grid-connected power plants. The baseline emissions are to be calculated as follows:

$$BE_y = EG_{PJ,y} \times EF_{grid,y}$$

$BE_y$  = Baseline emissions in year y (t CO<sub>2</sub>)

$EG_{PJ,y}$  = Quantity of net electricity generation that is produced and fed into the grid as a result of the implementation of the CDM project activity in year y (MWh)

$EF_{grid,y}$  = UCR recommended emission factor of 0.9 tCO<sub>2</sub>/MWh has been considered. (Reference: General Project Eligibility Criteria and Guidance, UCR Standard, page 4)

Estimated annual baseline emission reductions (BE<sub>y</sub>)

$$= 4,204 \text{ MWh/year} * 0.9 \text{ tCO}_2/\text{MWh}$$

$$= 3,784 \text{ tCO}_2/\text{year}$$

Hence Net GHG emission reduction, = 3,784-0-0 = 3,784 tCO<sub>2</sub>/year (i.e., 3,784 CoUs/year)

- **Project Emissions**

As per Paragraph 39 of AMS-I.D. version-18, only emissions associated with fossil fuel combustion, emissions from the operation of geothermal power plants due to the release of non-condensable gases, emissions from a water reservoir of Hydro should be accounted for the project emission. Since the project activity is a Hydro Electric Power project, project emission for renewable energy plants is nil.

**Thus, PE = 0**

- **Leakage Emission**

As per paragraph 42 of AMS-I.D. version-18, 'If the energy generating equipment is transferred from another activity, leakage is to be considered.' In the project activity, there is no transfer of energy-generating equipment and therefore the leakage from the project activity is considered zero.

**Hence, LE = 0**

The actual emission reduction achieved during the first CoU period shall be submitted as a part of the first monitoring and verification. However, for the purpose of an ex-ante estimation, the following calculation has been submitted:

## **B.6 Prior History**

The project activity is a small-scale hydro project and was not applied under any other GHG mechanism prior to this registration with UCR. Also, project has not been applied for any other environmental crediting or certification mechanism. Hence project will not cause double accounting

of carbon credits (i.e., COUs).

### B.7 Changes to the start date of crediting

There is no change in the start date of crediting period.

The start date of crediting under UCR is considered as 11/01/2021, which is the project commissioning date.

### B.8 Permanent changes from PCN monitoring plan, applied methodology or applied standardized baseline

Not applicable.

### B.9 Monitoring period number and duration

Total Monitoring Period: 20 Years

Date: 11/01/2021 to 31/12/2040 (inclusive of both dates).

### B.10 Monitoring Plan

#### Data and Parameters available (ex-ante values):

Data / Parameter	UCR recommended emission factor
Data unit	tCO <sub>2</sub> /MWh
Description	A "grid emission factor" refers to a CO <sub>2</sub> emission factor (tCO <sub>2</sub> /MWh) which will be associated with each unit of electricity provided by an electricity system. The UCR recommends an emission factor of 0.9 tCO <sub>2</sub> /MWh for the 2013 - 2020 years as a fairly conservative estimate for Indian projects not previously verified under any GHG program. Hence, the same emission factor has been considered to calculate the emission reduction under conservative approach.
Source of data	<a href="https://a23e347601d72166dcd616da518ed3035d35cf0439f1cdf449c9.ssl.cf2.rackcdn.com/Documents/UCRStandardAug2022updatedVer5_030822005728911983.pdf">https://a23e347601d72166dcd616da518ed3035d35cf0439f1cdf449c9.ssl.cf2.rackcdn.com/Documents/UCRStandardAug2022updatedVer5_030822005728911983.pdf</a>
Value applied	0.9
Measurement methods and procedures	-
Monitoring frequency	Ex-ante fixed parameter
Purpose of Data	For the calculation of Emission Factor of the grid
Additional Comment	The combined margin emission factor as per CEA database (current version 16, Year 2021) results into higher emission factor. Hence for

	2021 vintage UCR default emission factor remains conservative.
--	--

**Data and Parameters to be monitored (ex-post monitoring values):**

Data / Parameter	$EG_{PJ, facility, y}$
Data unit	MWh
Description	Net electricity supplied to the NEWNE grid facility by the project activity
Source of data	Joint Meter Reading report issued by state electricity board
Measurement procedures (if any):	<p>Data Type: Measured</p> <p>Monitoring equipment: Energy Meters are used for monitoring Recording Frequency: Continuous monitoring and Monthly recording from Energy Meters, Summarized Annually</p> <p>Archiving Policy: Paper &amp; Electronic</p> <p>Calibration frequency: 5 years (as per CEA provision)</p> <p>Generally, the calculation is done by the Authority/Discom and the project proponent has no control over the authority for the calculation. Therefore, based on the joint meter reading certificates/credit notes, the project shall raise the invoice for monthly payments. In case the monthly JMR provides net export quantity, the same will be directly considered for calculation. However, if the JMR does not directly provide “net electricity” units, then quantity of net electricity supplied to the grid shall be calculated using the parameters reflected in the JMR.</p> <p>For example, the difference between the measured quantities of the grid export and the import will be considered as net export:</p> $EG_{PJ,y} = EG_{Export} - EG_{Import}$
Measurement Frequency:	Monthly
Value applied:	4,204 (Ex-ante estimate)
QA/QC procedures applied:	Calibration of the Main meters will be carried out once in five (5) years as per National Standards (as per the provision of CEA, India) and faulty meters will be duly replaced immediately as per the provision of power purchase agreement.

	<p>Cross Checking:</p> <p>Quantity of net electricity supplied to the grid will be cross checked from the invoices raised by the project participant to the grid.</p>
Purpose of data:	The Data/Parameter is required to calculate the baseline emission.
Any comment:	Data will be archived electronically for a period of 36 months beyond the end of crediting period.